

SLIM-LINE RC FAN CONVECTOR.

INSTALLATION, OPERATING, MAINTENANCE & AFTER SALES MANUAL

Product Serial Number:

--	--	--	--	--	--	--	--	--	--

Please leave this manual with the end user.

Part Number: 1370064

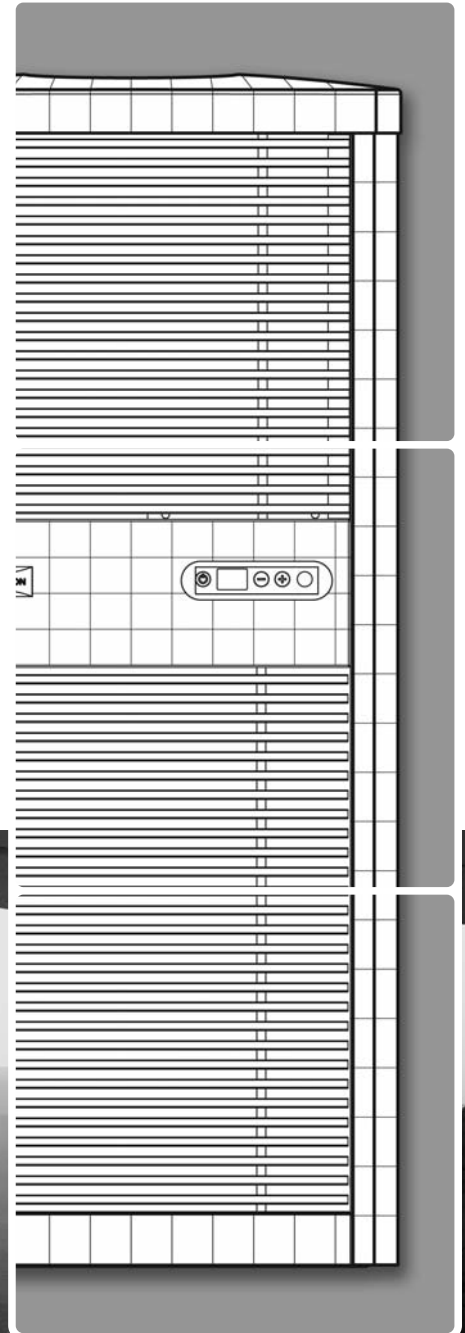

Contents

1.0	General Information	03
2.0	Heating System Design	03
3.0	Unit Selection/Sizing	03
4.0	Location	03
5.0	Preparation	04
6.0	Fixing	04
7.0	Water Connections	05
8.0	Electrical Connection	06
9.0	Commissioning Procedure	07
10.0	Technical Data	08
11.0	Operating Instructions	09
12.0	Troubleshooting	10
13.0	Maintenance	11

1.0 General Information

- This MYSON SLIM-LINE RC fan convector is designed for wall mounted installation with a minimum installation height of 150mm to the underside of the unit.
- The SLIM-LINE RC should only be used on closed circulation, two pipe, pump assisted central heating systems.
- The SLIM-LINE RC can be used on heat pump systems.
- The minimum side clearance is 100mm.
- The maximum ceiling height is 3m.
- Before proceeding with the installation, the heating system design must be considered and the unit correctly sized to meet the heat loss requirements of the room at normal fan speed.
- This unit is supplied with an infra red remote control system and has 3 operating modes:
Automatic – the desired room temperature is programmed in to the unit and the fan speed is automatically adjusted until the desired room temperature is achieved.

Fan only – allows user selection of any of the 3 available fan speeds irrespective of room temperature or water temperature in the coil.

Fan only with water temperature control – allows the user to select any of the available fan speeds, which will operate only if the water temperature in the coil is above 32°C. This enables control of the unit via an externally mounted room thermostat if desired.

- The appliance is not intended for use by persons (including children) with reduced physical, sensory or mental capabilities, or lack of experience and knowledge, unless they have been given supervision or instruction concerning use of the appliance by a person responsible for their safety.

Children should be supervised to ensure that they do not play with the appliance.

This unit **MUST NOT** be installed in a bathroom or other similar high humidity area.

2.0 Heating System Design

This fan convector must be fitted on a two pipe, pumped circulation heating system.

For optimum fan convector heating performance the system must be capable of providing sufficient hot water through the heat exchanger. This means that:

1. The minimum pipe size from boiler to fan convector must be 15mm.
2. **This unit is not suitable for use on microbore pipe-work.**
3. Where the unit is fitted on to a system with other emitters a separate circuit for the fan convector should be considered to provide adequate water flow.

4. The system water must be above 32°C for heating mode.

5. For heat pump applications - see Commissioning Procedure

6. **This unit is NOT suitable for one-pipe systems.**

7. **Optimum performance will require effective balancing of the whole system.**

8. This unit must not be used to replace a radiator in an existing system unless an adequate flow of water through the unit can be guaranteed.

3.0 Unit Selection/Sizing

Heat output performance is given in the Technical Data section of this manual. Outputs are shown for the three fan speeds, however, it is important to size the unit to match the calculated heat loss requirements of the room with the unit operating on the low fan speed. The higher fan speeds are used in automatic mode when the room temperature is significantly lower than the preset temperature.

When establishing the temperature difference, ie mean water to room temperature, allowance should be made for temperature drop in the system. It is the water temperature of the unit which dictates the output.

4.0 Location

- This SLIM-LINE RC unit may be fitted to any convenient wall at a height from floor level that suits the application, providing an unimpeded flow of warm air into the area to be heated.
- The minimum distance from the underside of the unit to floor level is 150mm.

- The unit should be mounted on a flat wall, and stud or partition walls should be avoided to minimise the possibility of noise transmission.

5.0 Preparation

Before proceeding with the installation, unpack the carton contents and check against the checklist below:

1. SLIM-LINE RC unit.
2. 15mm isolating valves (1 pair).
3. Instruction manual.
4. Warranty card.
5. Fixing kit (rubber mounts and cable gland).
6. Remote control handset.

6.0 Fixing

- Using the fixing dimensions (see fig. 1), mark the fixing hole positions on the wall.
- Drill and plug the wall for No. 8 x 40mm round head wood screws ensuring that the wall plugs are suitable for the wall type.
- Remove the backing from the self-adhesive washers and place on screws with adhesive side towards the point.
- Tighten the screws into the wall leaving about 9mm projecting.
- Press adhesive washers to the wall.
- Remove outer case fixing screw at the bottom of the unit (see fig. 2).
- Lift off outer case.
- Fit chassis on to retaining screws and tighten.

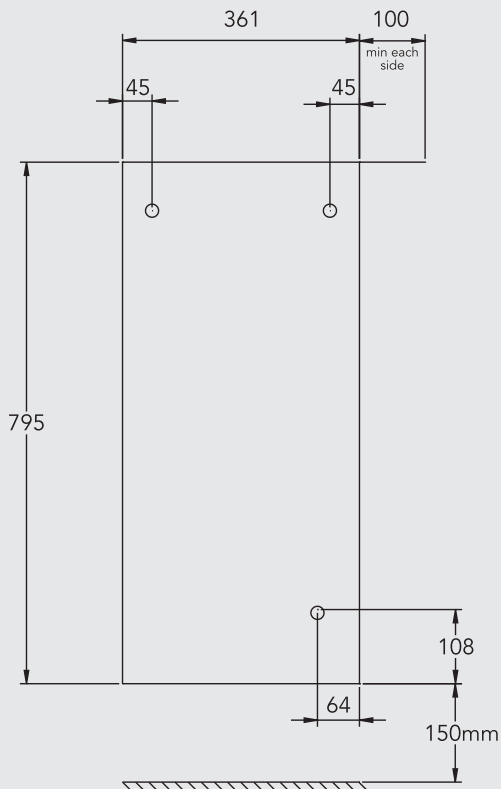

Fig. 1

7.0 Water Connections

- Connect unit to system flow and return pipes using the two 15mm isolating valves (see fig. 2).

Note: To ensure effective venting of the heat exchanger the flow pipe should be connected to the bottom connection of the heat exchanger.

Note: For SLIM-LINE RC installations pipe-work must not be routed directly underneath the unit as this will adversely affect the operation of the integral room thermostat. **If this cannot be avoided, the pipe-work must be boxed to prevent heat rise.**

- Ensure system is flushed in accordance with recognised best practice and a suitable inhibitor is added to the system as necessary.
- Open valves fully, check pipe connections for leaks and vent the heat exchanger - see Commissioning Procedure.

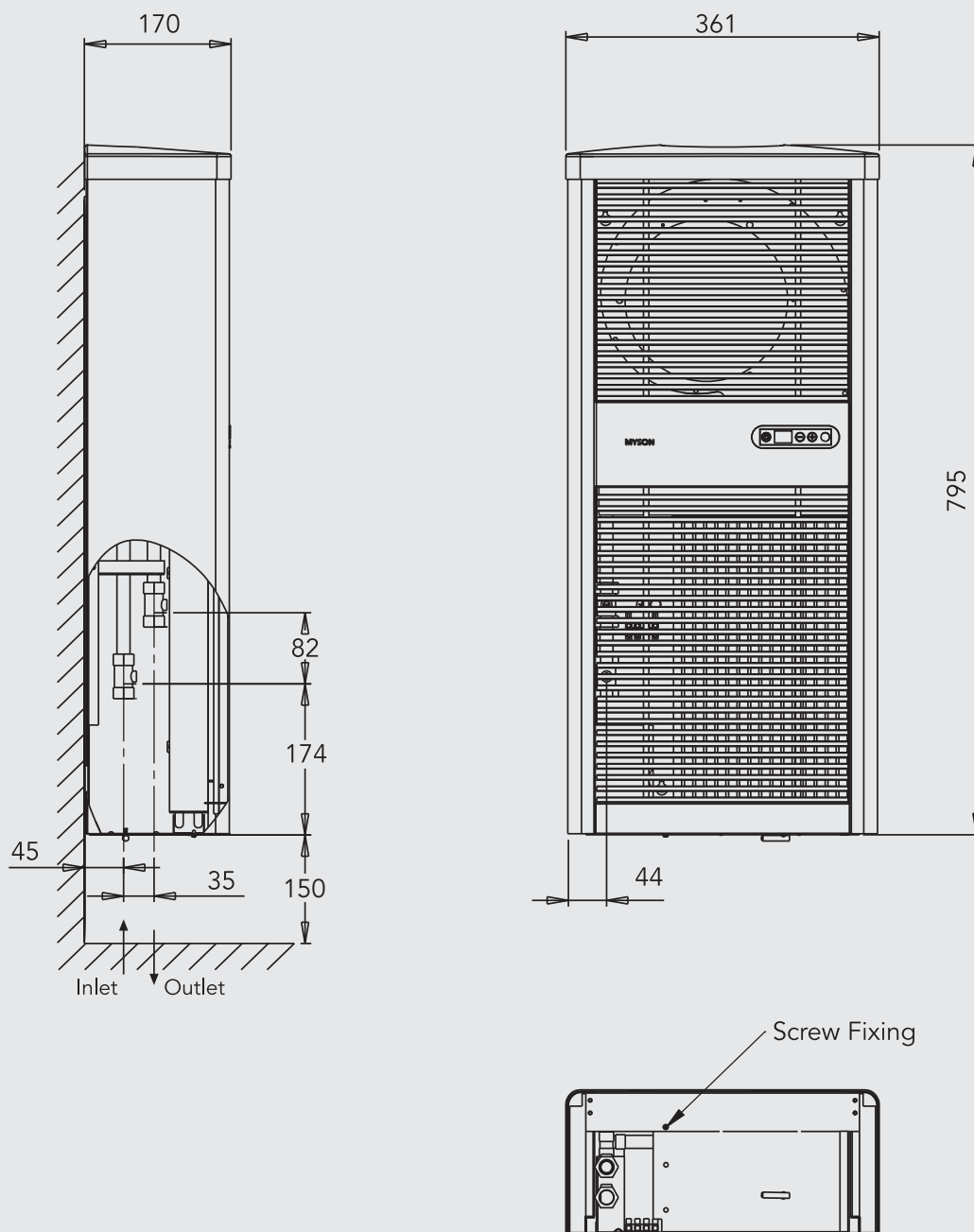

Fig. 2

8.0 Electrical Connection

WARNING: This appliance must be earthed. The electrical installation must comply with local or national wiring regulations.

- This unit is supplied with factory fitted test leads. Remove these and discard.
- A fused electrical spur with a maximum 3A fuse and a switch having 3mm separation on all poles must be provided in an easily accessible position adjacent to the unit.
- Electrical cable entry to the unit should be made through the underside of the unit using the cable gland provided, or through the hole provided at the upper right hand corner of the chassis.
- Connect live and neutral wires to the power board terminal connections, and the earth wire to the chassis earth terminal.

Wiring diagram

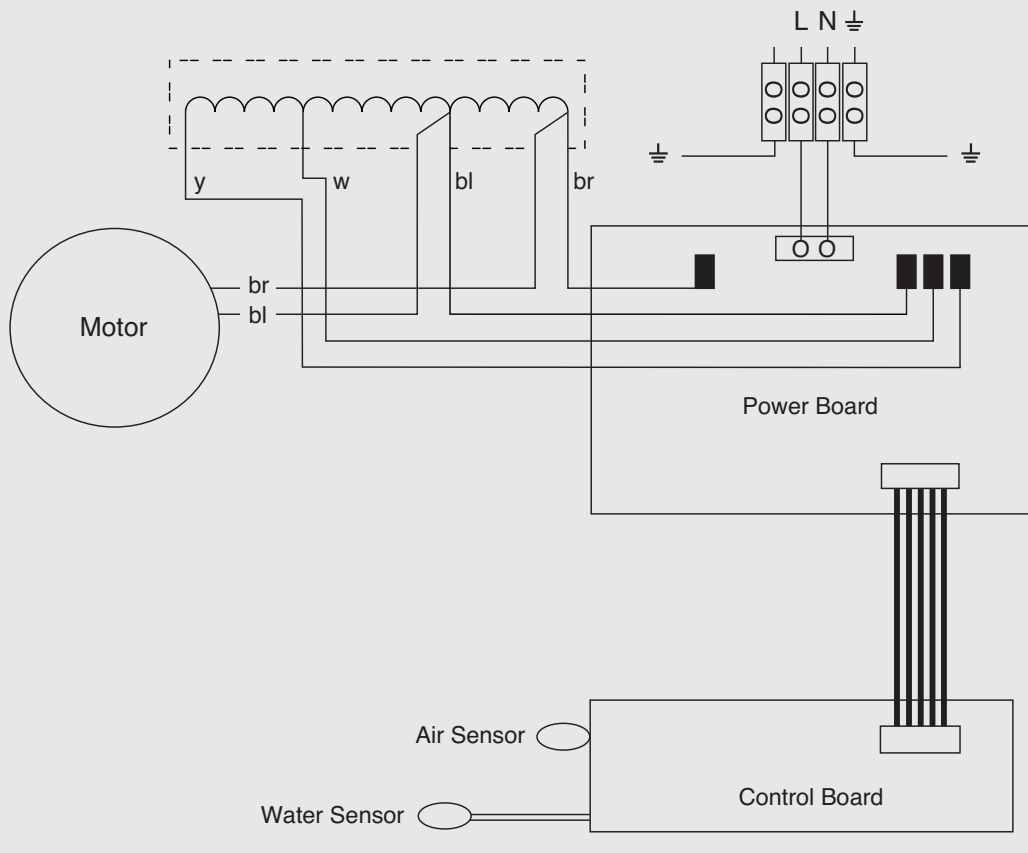

9.0 Commissioning Procedure

- Fill and vent the system.
- Open both valves fully and vent air from the heat exchanger by unscrewing the air bleed valve situated above the valves in the angled top of the chassis.
- Check for leaks at pipe connections.
- Refit the outer case and secure using the 2 fixing screws.
- Switch on electrical supply.
- Check the operation of the unit in automatic and manual modes by following the operating instructions.
- When installation and commissioning are complete, hand over instruction manual to end-user.

Heat Pump and Low Water Temperature Systems

In heating mode, the control system brings the fan on when the water in the coil reaches 32°C. For low water temperature systems, eg heat pump systems, it is possible to switch off the boost speed option in automatic mode so that the unit runs in medium or normal fan speeds depending on demand. This means low outlet air temperatures from the unit are avoided when the room temperature is low in relation to the set temperature.

This facility can be switched on or off by following the instructions:

- Isolate electrical supply.
- Remove outer cover.
- Change switch 1 position according to requirements (see fig. 3).
- Refit outer cover.
- Switch on electrical supply.

Displayed Temperature Calibration

Depending on the location of the unit there may be a difference between the temperature at the unit and the temperature in the middle of the room being heated.

The displayed temperature calibration function enables calibration in heating mode of the displayed temperature to the actual room temperature using the following procedure:

- Press the 'On/Off' key and '+' key for 5 seconds (the display will flash, alternating between 'ro' and the calibration temperature).
- Calibrate the displayed room temperature by using the '+' and '-' keys with the fan running.
- Press the 'On/Off' key to finish

Switch		Switch Down	Switch Up
1	Auto Fan Speed Selection	2 Speed	3 Speed
2	Heating	Heating	N/A
3	Fan Pulse	Off	On
4	Temperature Display	°F	°C

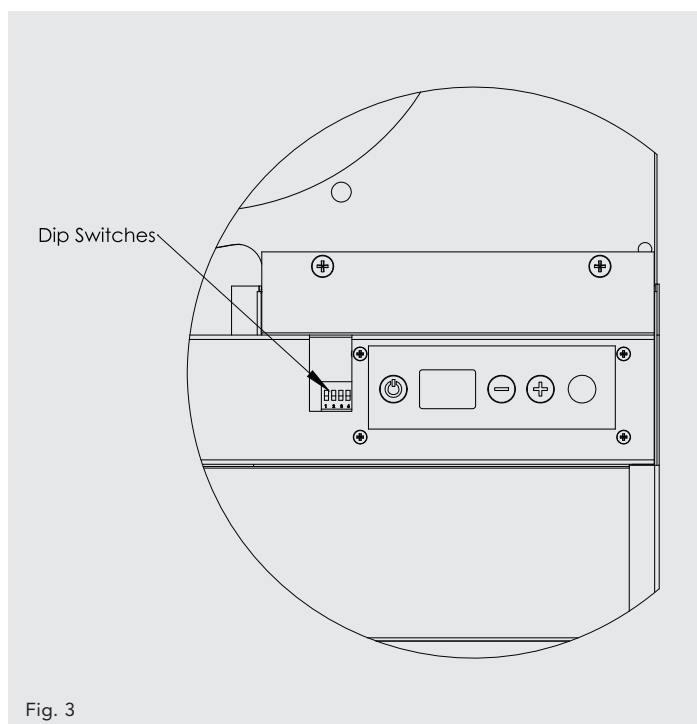

Fig. 3

10.0 Technical Data

Heating Performance Data

Power Consumption (watts)	Fan Speed	Temperature Difference (°C)									
		Heat Output (watts)					Heat Output (Btu/h)				
		20°	30°	40°	50°	60°	20°	30°	40°	50°	60°
125	Normal	860	1340	1820	2290	2770	2934	4572	6210	7813	9451
	Medium	1130	1710	2280	2870	3460	3856	5835	7779	9792	11806
	Boost	1470	2220	2960	3720	4460	5013	7575	10100	12693	15218

Tested in accordance with BS 4856 Part 1.
Flow rate 340 ltr/h (75 gal/h).

Flow Rate Correction Factors:

455 ltr/h (100 gal/h) multiply by 1.03

227 ltr/h (50 gal/h) multiply by 0.96

113 ltr/h (25 gal/h) multiply by 0.85

Electrical supply 230V 50Hz

Test pressure 20bar (1MPa)

Max working pressure 10bar (1MPa)

Water connections 15mm compression

Unit weight dry 14.3kg

Water capacity 0.51 litres

Approximate Hydraulic Resistance through Fan Convectors

Litres/h	mm wg	kPa
455	1771	17.4
340	1161	11.4
227	561	5.5
113	201	2.0

Noise levels in accordance with EN 23741

Fan Setting	Sound Pressure at 2.5m (dBA)
Normal	21.9
Medium	30.6
Boost	39.7

11.0 Operating Instructions

Description

This SLIM-LINE RC unit is fitted with a control system that provides 3 different operating modes. In automatic mode the desired temperature set point is selected and the unit will adjust the fan speed according to the difference between the actual room temperature and the set point. When the room temperature reaches the set point the fan will switch off and thereafter will continue to cycle on and off to maintain the room temperature. The temperature set point range is 15 - 35°C.

In manual mode the automatic temperature control is overridden and any of the three fan speeds can be operated irrespective of the water temperature in the unit. This means that air circulation can be provided in summer for example, or that heating performance can be controlled manually.

In manual mode, with water temperature control, any of the 3 fan speeds can be selected and the fan will operate when the water temperature in the coil is greater than 32°C. This means that heating performance can be controlled manually, and the unit could be controlled via an external room thermostat.

The unit can be controlled using the infrared remote control handset supplied with the unit (see fig. 4) and also using the control panel on the unit (see fig. 5). If necessary, however, the control panel can be locked electronically to prevent tampering once the controls have been set (see overleaf).



Fig. 4

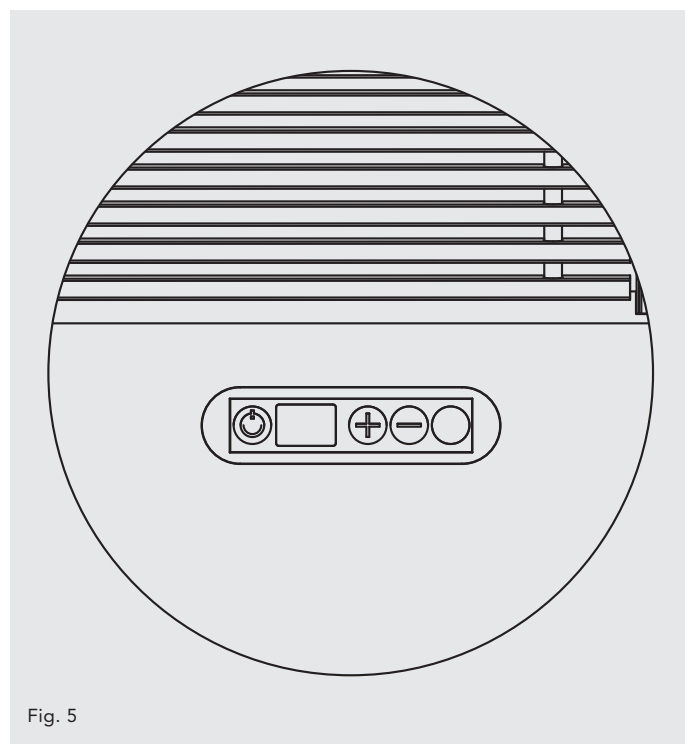

Fig. 5

The remote control hand set takes 2 AAA batteries (not supplied).

Controls

- Power button
- '+/-' button







Display

- Switches unit on & off
- Adjust temperature set point from 15 - 35°C
- Scrolls into F1, F2 or F3 manual mode

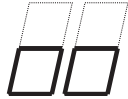
Heating

The unit will only operate in heating mode when the central heating boiler is on, the pump is running and the system water temperature is greater than 32°C. Ensure the boiler is on, and set timer, boiler controls and room thermostats as necessary.

11.0 Operating Instructions (continued...)

Operation	Display
Power off	No Display
Switch on supply to unit (unit off)	 for 30 seconds
Switch on unit	 Supply on / unit off
Use '+/-' to adjust set point	 Set point flashes for approx 5 secs, then
	 Ambient temperature displayed
	 Set point flashes for approx 5 secs, then
	 Ambient temperature
The ambient temperature is always displayed unless the water temperature falls below 32°C, or if the set point is being adjusted.	
Water temp <32°C	 Shows both power & unit on

Manual

Manual mode can be used for air circulation without heat or for manual control of the heating function.

Use '+' to scroll beyond 35°C
Or use '-' to scroll below 15°C

Selected fan speed displayed

 Continuous fan only

 Fan & water temperature (water inlet >32°C)

Scrolling back out of manual using the '+' or '-' button will revert the unit back to last temperature set point.

Locking Unit Controls

The control panel on the main unit can be locked electronically to prevent interference once the controls have been set. After setting the unit to the desired temperature setting and with the unit in running mode, press the On/Off button on the main unit for about 6 seconds until the two middle horizontal bars appear on the display. The horizontal bars will disappear after about 6 seconds and the unit is in key lock mode.

If any of the unit controls are pressed the horizontal bars will reappear to show the key lock mode is activated, however, during this mode the handset controls remain functional.

To unlock the system press the On/Off button for about 6 seconds until the horizontal bars disappear.

12.0 Troubleshooting

Once installed this fan convector becomes part of a complete heating system that will generally include a boiler, pump, other emitters such as radiators and fan convectors, and a number of heating controls, dependent on system complexity. An apparent problem with this unit may be the result of system controls being incorrectly set and can be solved easily without calling out your installer or MYSON Service. Before calling your installer or MYSON Service, please carry out the checks listed opposite.

Note: If you call out MYSON Service to a fault detailed opposite, or to repair a fault caused by incorrect use, a call out charge will be made.

12.0 Troubleshooting (continued...)

Problem	Possible Causes	Remedy
Heating Mode - No Fan	Unit switched off	Turn on
	Temperature set point reached	Increase temperature set point
	Unit not switched on at fused spur	Switch on at spur
	Fuse blown at fused spur	Replace fuse
	Unit isolating valves shut	Open valves
	Water temperature reaching fan convector below 32°C	Check boiler - Programmer ON Boiler ON and set to high with central heating pump running Note: Operation of fan convector can be checked by switching to manual fan setting
Heating Mode - Poor heating performance and/or unit cycles on water sensor	Low water temperature to unit	Turn up boiler thermostat
	Poor water flow	Vent air from heating system Note: Operation of fan convector can be checked by switching to manual fan setting

If the fan convector is still faulty after checking the above, call your installer or MYSON Service.

Common Installation Faults

For optimum performance, this unit must be correctly sized to match the heat loss requirements of the space it is required to

heat, and the heating system must be correctly designed to provide adequate flow of hot water to the unit (refer to section 2). If the recommendations in section 2 are not followed, problems may arise as detailed below.

Problem	Possible Causes
Poor heating performance	Unit incorrectly sized for heat loss of room
Heating Mode - Poor heating performance and/or unit cycles on water sensor	Boiler thermostat set too low
	Lack of flow to fan convector
	Pump set on low setting
	Isolating valves not fully open
	System incorrectly balanced with unit starved of hot water flow
	Pipe sizing to unit too small

13.0 Maintenance

Before undertaking any maintenance activity isolate the electrical supply.

Maintenance should be restricted to occasional removal of dust and lint around the unit. The outer surface may be wiped over

with warm water and mild detergent taking care to avoid water entering the grille areas.



Serial Number Location:

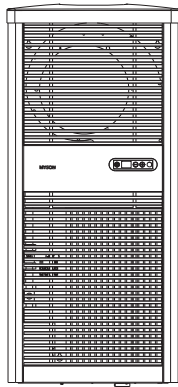

Inner chassis position ↑

After Sales Service:

MYSON Service, Somerden Road, Hull, East Yorkshire HU9 5PE
T: 01482 713927, F: 01482 789056, service.convectors@myson.co.uk

Spare parts and technical help on all Convector products is available from MYSON Service.



heatingthrough**innovation.**